

**Межгосударственный стандарт ГОСТ 17375-2001 (ИСО 3419-81)
"Детали трубопроводов бесшовные приварные из углеродистой
и низколегированной стали. Отводы крутоизогнутые типа 3D
(R приблизительно = 1,5 DN). Конструкция"
(введен в действие постановлением Госстандарта РФ
от 27 мая 2002 г. N 205-ст)**

**Carbon and low-alloy steel butt-welding fittings, curved bends type 3D (R приблизительно = 1,5 DN).
Design**

Взамен ГОСТ 17375-83
Дата введения 1 января 2003 г.

- [1. Область применения](#)
- [2. Нормативные ссылки](#)
- [3. Определения, обозначения и сокращения](#)
- [4. Конструкция и размеры](#)
- [5. Технические условия](#)

1. Область применения

Настоящий стандарт распространяется на бесшовные приварные отводы из углеродистой и низколегированной стали типа 3D с R приблизительно = 1,5 DN и тета = 45°, тета = 60°, тета = 90° и тета = 180°, изготавливаемые из труб методами штамповки или протяжки по рогообразному сердечнику.

Область применения отводов - в соответствии с разделом 1 ГОСТ 17380.

Требования [пункта 4.1](#) и [раздела 5](#) являются обязательными, остальные требования - рекомендуемыми.

2. Нормативные ссылки

В настоящем стандарте использована ссылка на ГОСТ 17380-2001. Детали трубопроводов бесшовные приварные из углеродистой и низколегированной стали. Общие технические условия

3. Определения, обозначения и сокращения

Термины, их определения, обозначения и сокращения - по [ГОСТ 17380](#).

4. Конструкция и размеры

4.1 Конструкция и размеры отводов должны соответствовать указанным на [рисунке 1](#) и в [таблицах 1](#) и [2](#).



Рисунок 1

"Рисунок 1"

Таблица 1 - Отводы исполнения 1

Размеры в миллиметрах

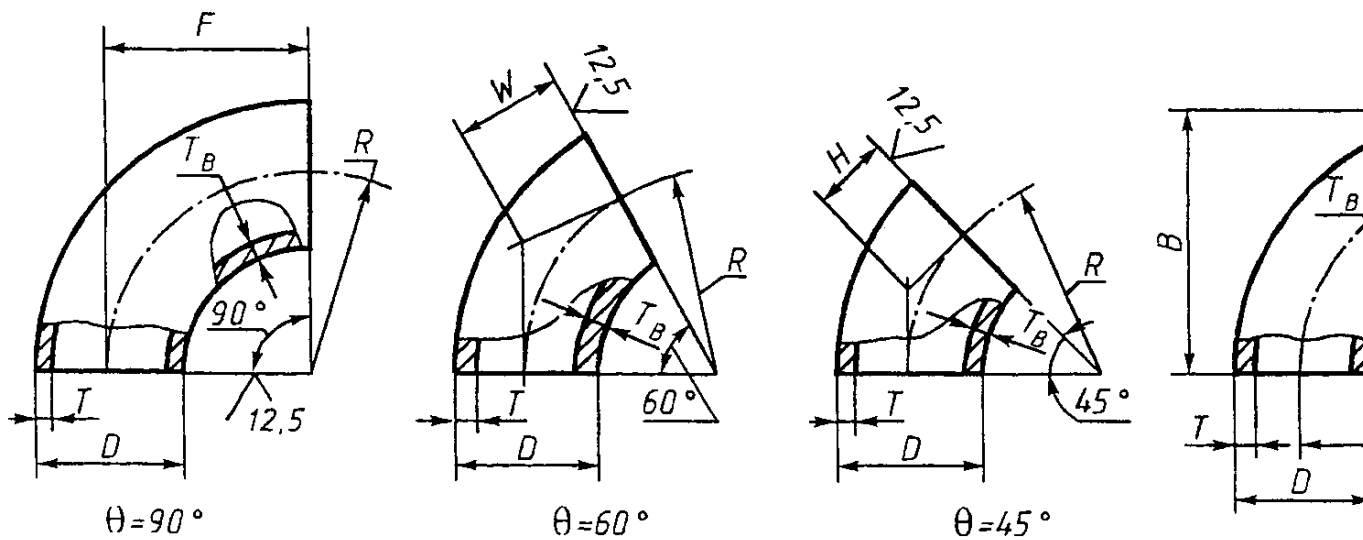
DN	D	T	F = R	H	C	B	Масса, кг, отвода с тета		
							45°	90°	180°
15	21,3	2,0	28	14	56	38	0,02	0,04	0,08
		3,2					0,03	0,06	0,12
		4,0					0,04	0,07	0,14
20	26,9	2,0	29	14	58	43	0,03	0,06	0,11
		3,2					0,04	0,08	0,17
		4,0					0,06	0,10	0,20
25	33,7	2,3	38	18	76	56	0,05	0,11	0,21
		3,2					0,08	0,16	0,32
		4,5					0,09	0,19	0,38
32	42,4	2,6	48	23	96	69	0,10	0,19	0,39
		3,6					0,13	0,26	0,52
		5,0					0,17	0,35	0,60
40	48,3	2,6	57	29	114	82	0,13	0,26	0,53
		3,6					0,18	0,36	0,72

		5,0					0,24	0,47	0,95
50	60,3	2,9	76	35	152	106	0,25	0,50	0,99
		4,0					0,33	0,67	1,30
		5,6					0,50	0,89	1,80
65	76,1	2,9	95	44	190	133	0,40	0,79	1,60
		5,0					0,72	1,50	2,90
		7,1					0,90	1,80	3,60
80	88,9	3,2	114	51	228	159	0,60	1,20	2,40
		5,6					1,00	2,10	4,10
		8,0					1,40	2,80	5,70
100	114,3	3,6	152	64	304	210	1,20	2,40	4,70
		6,3					2,00	4,00	8,00
		8,8					2,80	5,40	11,00
125	139,7	4,0	190	79	380	260	2,00	4,00	8,00
		6,3					3,10	6,20	12,00
		10,0					4,80	9,60	19,00
150	168,3	4,5	229	95	457	313	3,20	6,50	13,00
		7,1					5,10	10,00	20,00
		11,0					7,70	15,00	31,00
200	219,1	6,3	305	127	610	414	8,00	16,00	32,00
		8,0					9,90	20,00	40,00
		12,5					14,00	31,00	61,00
250	273,0	6,3	381	159	762	518	12,00	25,00	50,00
		10,0					19,00	39,00	78,00
300	323,9	7,1	457	190	914	619	20,00	40,00	80,00
		10,0					28,00	56,00	111,00
350	355,6	8,0	533	222	1066	711	24,00	57,00	114,00
		11,0					39,00	78,00	156,00
400	406,4	8,8	610	254	1220	813	41,00	82,00	165,00
		12,5					58,00	117,00	234,00
450	457,0	10,0	686	286	1372	914	59,00	119,00	237,00

500	508,0	11,0	762	318	1524	1016	81,00	162,00	323,00
600	610,0	12,5	914	381	1828	1219	133,00	266,00	531,00
700	711,0	-	1067	444	2134	1422	-	-	-
800	813,0	-	1219	507	2238	-	-	-	-
900	914,0	-	1372	570	2744	-	-	-	-
1000	1016,0	-	1524	634	3048	-	-	-	-

Примечания

1 Масса приведена для справок.

2 Отводы с тета = 60° исполнения 1 не предусматриваются.

Таблица 2 - Отводы исполнения 2

Размеры в миллиметрах

DN	D	T	F = R	W	H	C	B	Масса отвода с тета = 90°, кг
25	32	2,0	38	22	18	76	56	0,1
		2,5						0,2
		3,0						0,2
		3,5						0,2
32	38	2,0	48	28	23	96	69	0,2
		2,5						0,2
		3,0						0,2
		3,5						0,3
		4,0						0,3
40	45	2,5	60	35	25	120	83	0,3
		3,0						0,3
		3,5						0,4
		4,0						0,4
		5,0						0,5
50	57	2,5	75	43	80	150	104	0,4
		3,0						0,5
		3,5						0,6
		4,0						0,7

		4,5						0,7
		5,0						0,8
		5,5						0,9
		6,0						1,0
65	76	3,0	100	57	41	200	138	0,8
		3,5						1,0
		4,0						1,1
		4,5						1,3
		5,0						1,4
		5,5						1,6
		6,0						1,7
		7,0						2,0
		8,0						2,2
80	89	3,0	120	69	50	240	165	1,2
		3,5						1,4
		4,0						1,5
		4,5						1,7
		5,0						1,9
		5,5						2,1
		6,0						2,3
		7,0						2,7
		8,0						3,0
100	102	3,5	150	87	62	300	201	2,1
		4,0						2,4
		4,5						2,6
		5,0						2,9
		6,0						3,4
		7,0						3,9
		8,0						4,5
		9,0						5,0

		10,0						5,5
	108	3,5					204	2,2
		4,0						2,5
		4,5						2,8
		5,0						3,1
		6,0						3,6
		7,0						4,1
		8,0						4,7
		9,0						5,3
		10,0						5,8
	114	3,5					207	2,2
		4,0						2,6
		4,5						2,9
		5,0						3,3
		6,0						3,8
		7,0						4,4
		8,0						5,0
		9,0						5,7
		10,0						6,1
125	133	3,5	190	110	79	380	257	3,3
		4,0						3,8
		4,5						4,3
		5,0						4,8
		6,0						5,7
		7,0						6,5
		8,0						7,4
		9,0						8,2
		10,0						9,1
		11,0						10,0
		12,0						11,0
150	159	4,0	225	130	93	450	305	5,4

		4,5						6,1
		5,0						6,7
		6,0						8,1
		7,0						9,4
		8,0						11,0
		9,0						12,0
		10,0						13,0
		11,0						14,0
		12,0						16,0
		13,0						17,0
		14,0						18,0
	168	4,0						5,6
		4,5						6,4
		5,0						7,1
		6,0						8,5
		7,0						9,8
		8,0						11,2
		9,0						12,5
		10,0						14,0
		11,0						15,0
		12,0						16,0
		13,0						17,5
		14,0						19,0
200	219	5,0	300	173	124	600	410	13,0
		6,0						15,0
		7,0						17,0
		8,0						20,0
		9,0						22,0
		10,0						25,0
		11,0						27,0

		12,0						29,0
		13,0						32,0
		14,0						34,0
		15,0						37,0
		16,0						39,0
		17,0						42,0
		18,0						44,0
250	273	6,0	375	217	155	750	512	23,0
		7,0						27,0
		8,0						31,0
		9,0						35,0
		10,0						39,0
		11,0						43,0
		12,0						46,0
		13,0						50,0
		14,0						54,0
		15,0						58,0
		16,0						61,0
		17,0						66,0
		18,0						70,0
		20,0						78,0
		22,0						85,0
300	325	7,0	450	260	186	900	613	39,0
		8,0						45,0
		9,0						50,0
		10,0						56,0
		11,0						61,0
		12,0						66,0
		13,0						72,0
		14,0						77,0
		15,0						82,0

		16,0						87,0
		17,0						92,0
		18,0						96,0
		20,0						107,0
		22,0						118,0
		24,0						130,0
		26,0						141,0
		28,0						150,0
350	377	9,0	525	303	217	1050	714	68,0
		10,0						75,0
		11,0						83,0
		12,0						90,0
		13,0						97,0
		14,0						104,0
		15,0						112,0
		16,0						119,0
		18,0						133,0
		20,0						147,0
		22,0						161,0
		24,0						175,0
		26,0						188,0
		28,0						201,0
		30,0						214,0
		32,0						228,0
400	426	8,0	600	346	248	1200	813	78,0
		9,0						87,0
		10,0						97,0
		11,0						107,0
		12,0						117,0
		13,0						126,0

		14,0						135,0
		15,0						145,0
		16,0						154,0
		17,0						164,0
		18,0						173,0
		20,0						192,0
		22,0						210,0
		24,0						230,0
		26,0						249,0
		28,0						268,0
		30,0						286,0
		32,0						306,0
		34,0						324,0
500	530	9,0	750	433	310	1500	1015	138,0
		10,0						153,0
		11,0						168,0
		12,0						183,0
		13,0						198,0
		14,0						212,0
		15,0						227,0
		16,0						242,0
		17,0						256,0
		18,0						270,0
		20,0						298,0
		22,0						327,0
		24,0						356,0
		26,0						385,0
		28,0						413,0
		30,0						440,0
		32,0						467,0
		34,0						494,0

		36,0						520,0
600	630	9,0	900	519	373	1800	1215	198,0
		10,0						219,0
		11,0						245,0
		12,0						261,0
		13,0						282,0
		14,0						302,0
		15,0						324,0
		16,0						345,0
		17,0						366,0
		18,0						387,0
		20,0						429,0
		22,0						471,0
		24,0						513,0
		26,0						554,0
		28,0						595,0
		30,0						636,0
		32,0						678,0
700	720	9,0	1000	577	404	2000	1360	248,0
		10,0						275,0
		11,0						302,0
		12,0						329,0
		13,0						356,0
		14,0						383,0
		15,0						410,0
		16,0						436,0
		17,0						462,0
		18,0						489,0
		20,0						542,0
		22,0						595,0

		24,0						647,0
		26,0						698,0
		28,0						750,0
		30,0						801,0
		32,0						852,0
800	820	9,0	1200	693	485	2400	1610	339,0
		10,0						376,0
		11,0						413,0
		12,0						450,0
		13,0						487,0
		14,0						524,0
		15,0						561,0
		16,0						598,0
		17,0						636,0
		18,0						670,0
		20,0						743,0
		22,0						815,0
		24,0						887,0
		26,0						959,0
		28,0						1030,0
		30,0						1101,0
		32,0						1171,0

Примечания

1 Масса приведена для справок.

2 Масса отводов с тета = 60° и тета = 45° соответственно в 1,5 и 2 раза меньше, а отводов с тета = 180° в 2 раза больше указанной.

Примеры условных обозначений:

- отвода с тета = 90°, исполнения 1, D = 139,7 мм, T = 4,0 мм из стали марки TS4:

Отвод 90-1-139,7 x 4-TS4 ГОСТ 17375-2001

- отвода с тета = 45°, исполнения 2, D = 159 мм, T = 4,0 мм, T_в = 6,0 мм из стали марки 20:

Отвод 45-159 x 4/6 ГОСТ 17375-2001

- отвода с тета = 90°, исполнения 2, D = 57 мм, T = 5,0 мм из стали марки 09Г2С:

Отвод 90-57 x 5-09Г2С ГОСТ 17375-2001

- то же, для трубопроводов, подконтрольных органам надзора:

Отвод П90-57 x 5-09Г2С ГОСТ 17375-2001

4.2 По согласованию между изготовителем и потребителем (заказчиком) допускается изготовление отводов исполнения 2 с другими размерами и углами тета.

4.3 Допускается изготовление отводов исполнения 2 с увеличенной толщиной стенки в неторцевых сечениях Т_в.

5. Технические условия

Технические условия - по ГОСТ 17380.